

## Ecophon Focus Levels

600x600  
1200x300  
1200x600  
**M488/M489**

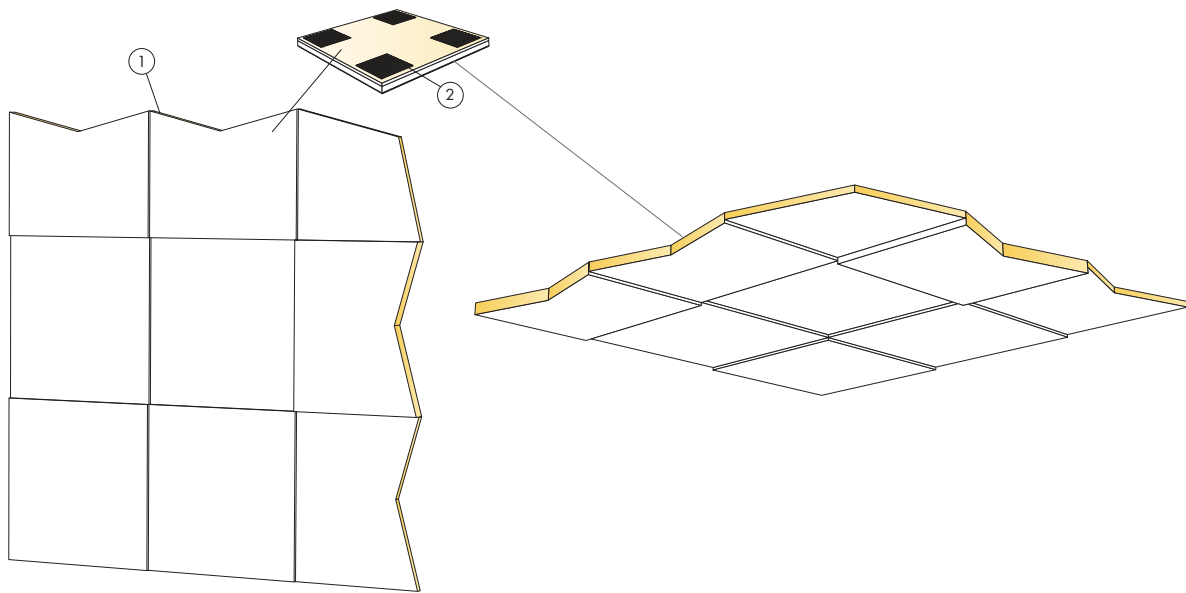

1. Ecophon Focus Levels

2. Connect Absorber glue



3. Connect Notched spatula



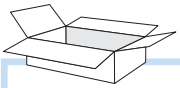

Connect Absorber glue



x1

1

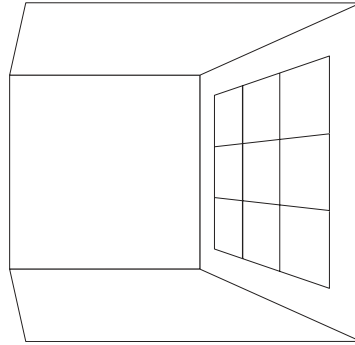

7

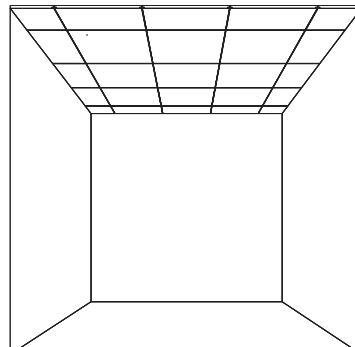

Ensure a smooth, clean, dry strong surface before installation.  
Suitable surfaces are plasterboard, concrete, light concrete or building board.  
Avoid surfaces which are sensitive to moisture or water. The surface, the tiles and the glue must be at a temperature of 10-25 °C.

In case of doubt or uncertainty, an adhesion test should be carried out prior to the installation. Please contact your Ecophon representative.



Step-by-step installation video available on [ecophon.com](http://ecophon.com)

**Ecophon**  
SAINT-GOBAIN

[www.ecophon.com](http://www.ecophon.com)

# 1

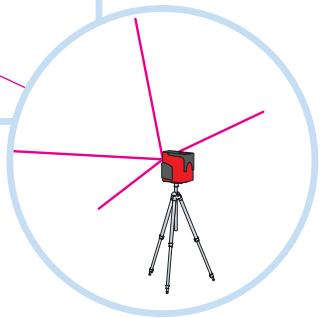
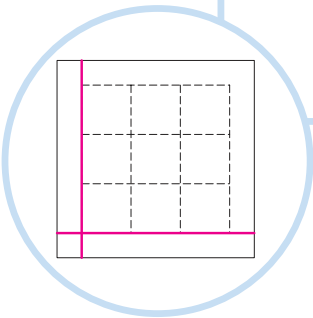
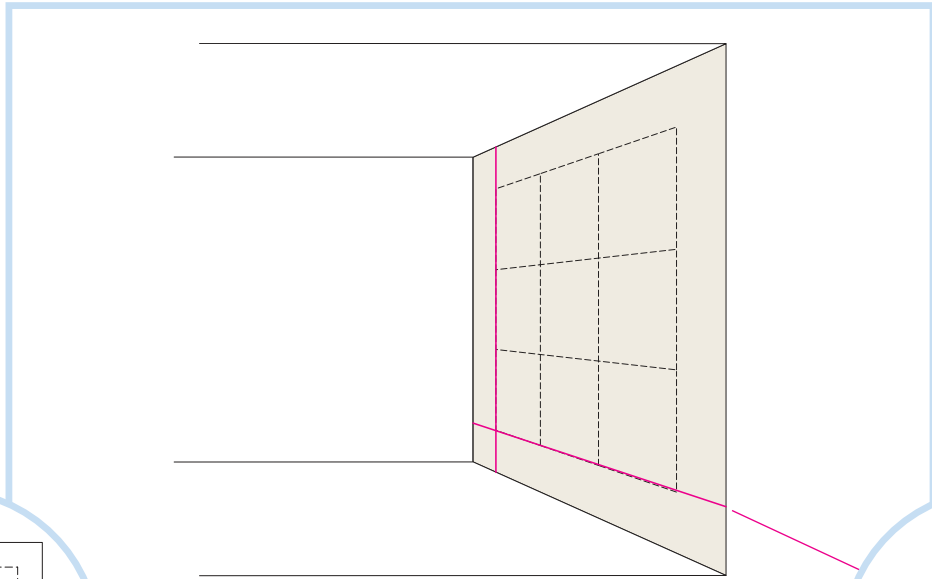

# 2

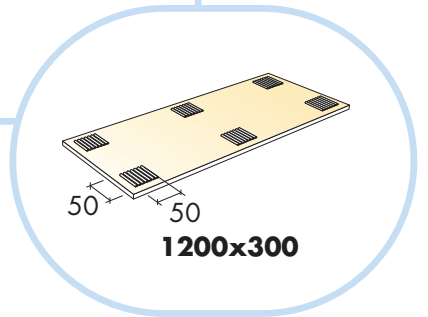
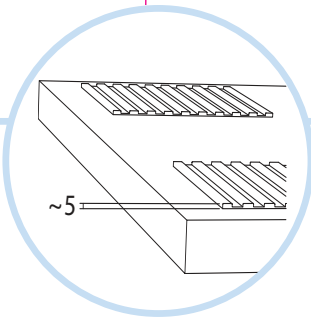
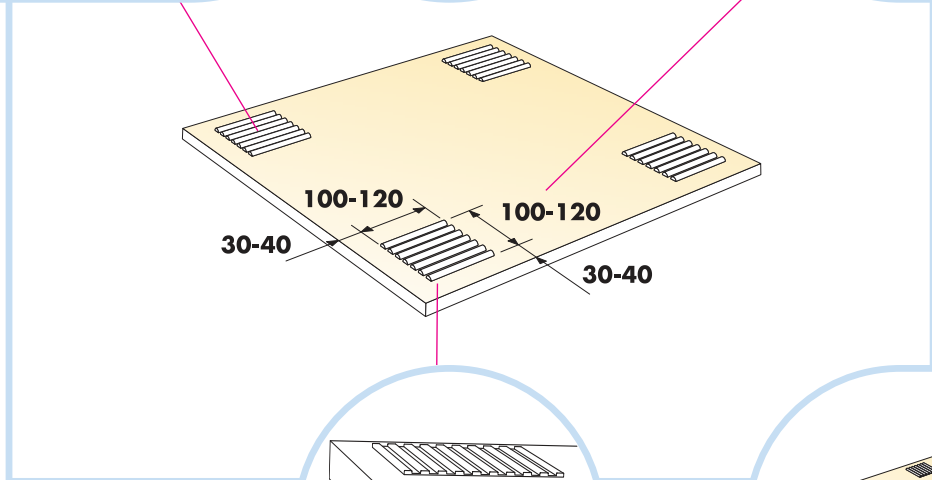
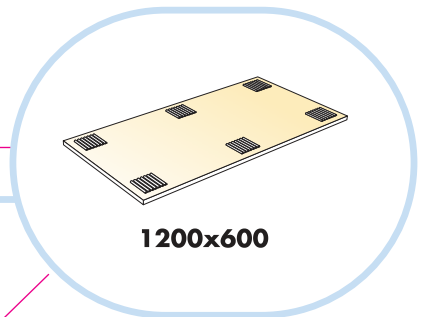
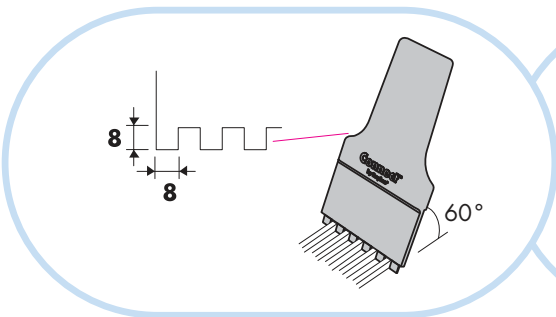

3

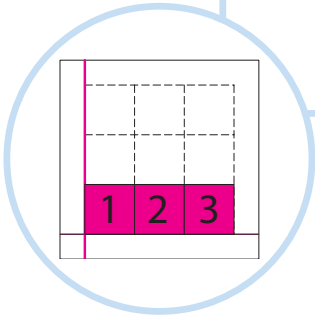
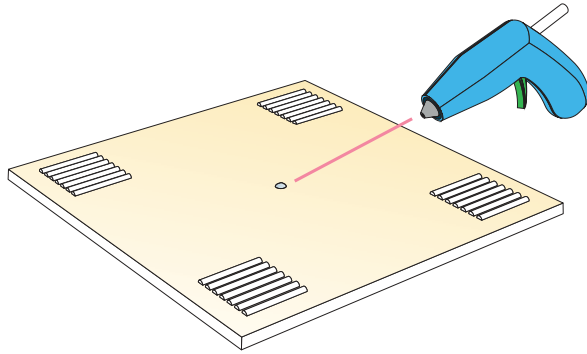

4

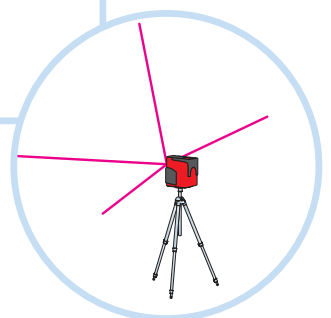
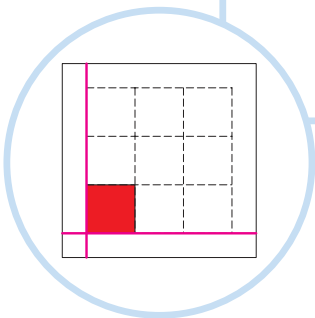
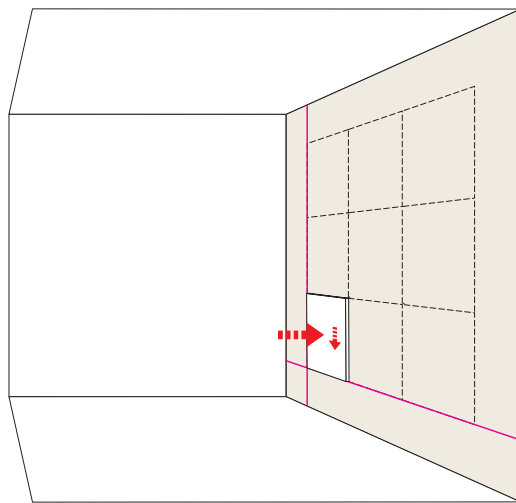

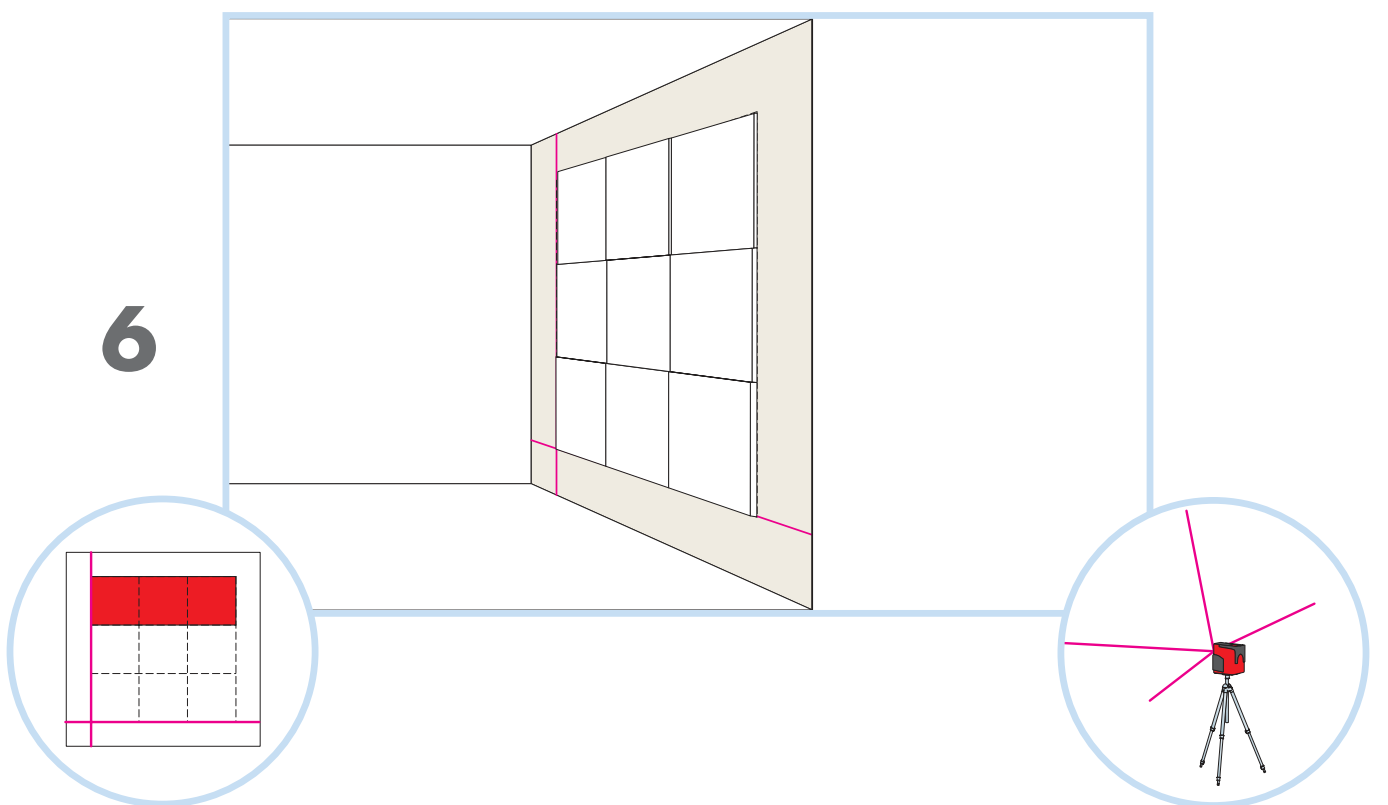
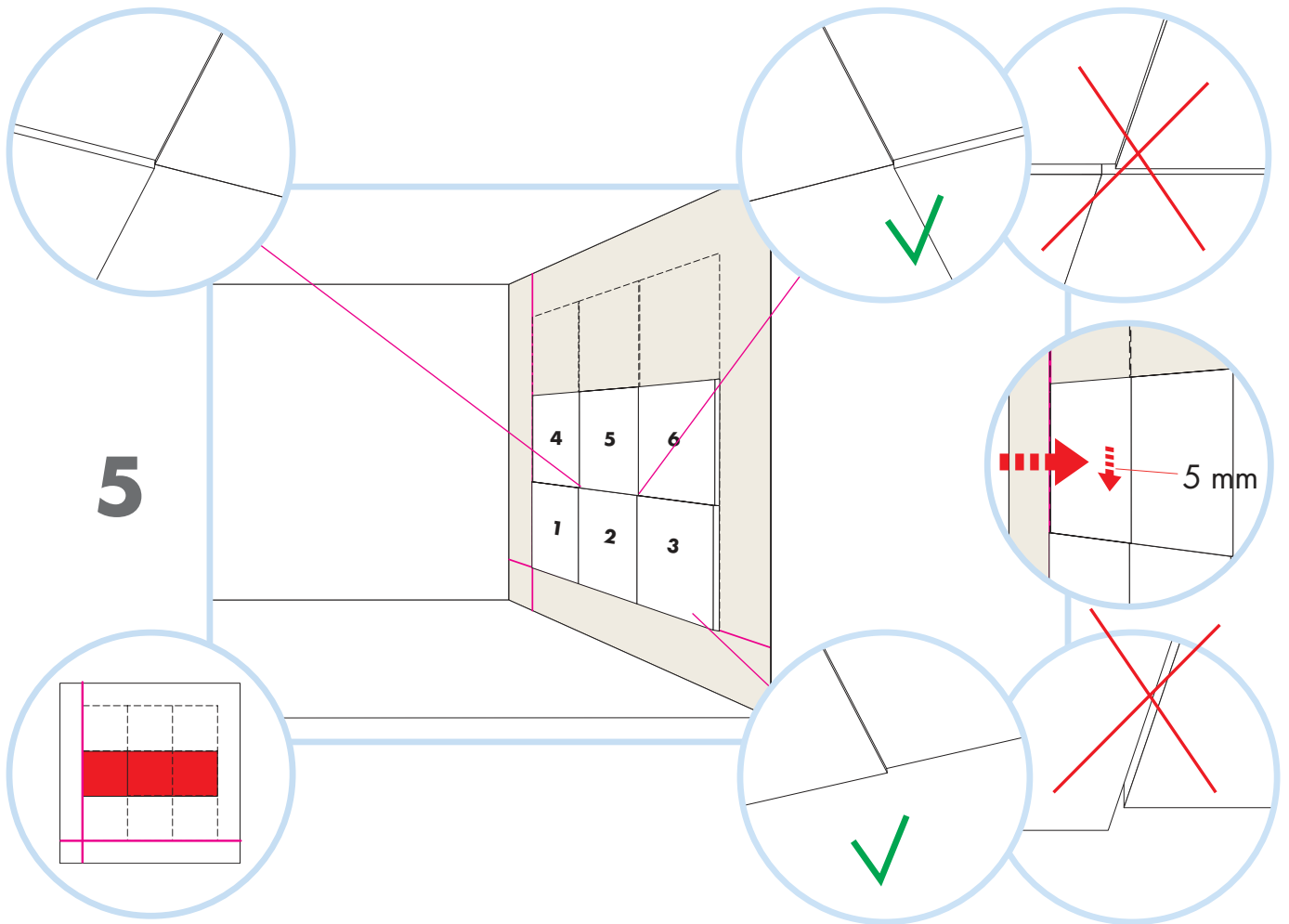

7

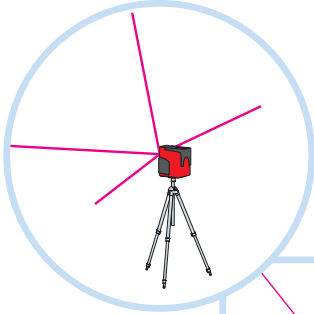
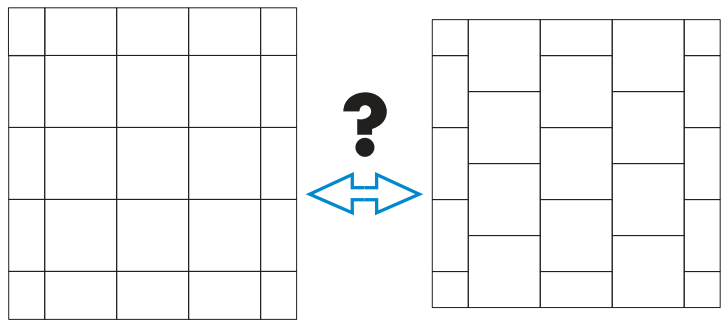
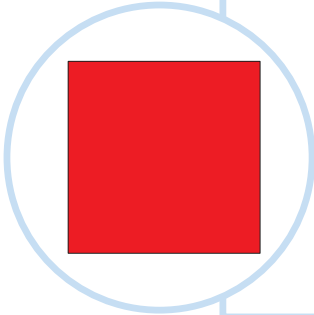
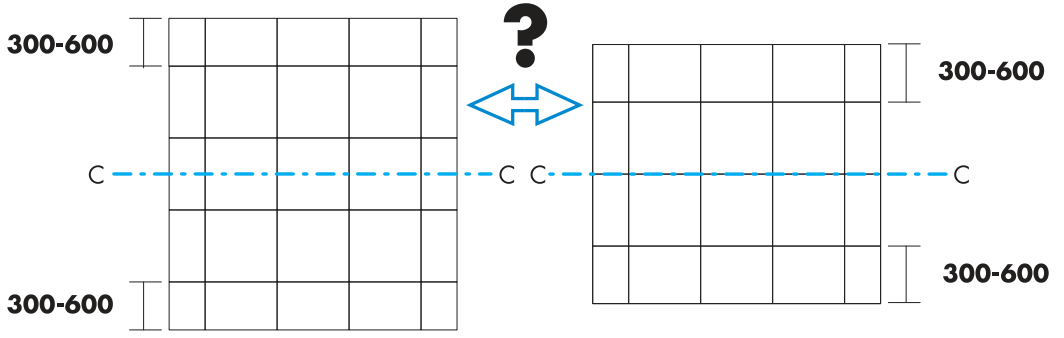

8

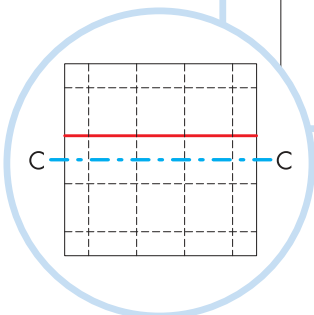
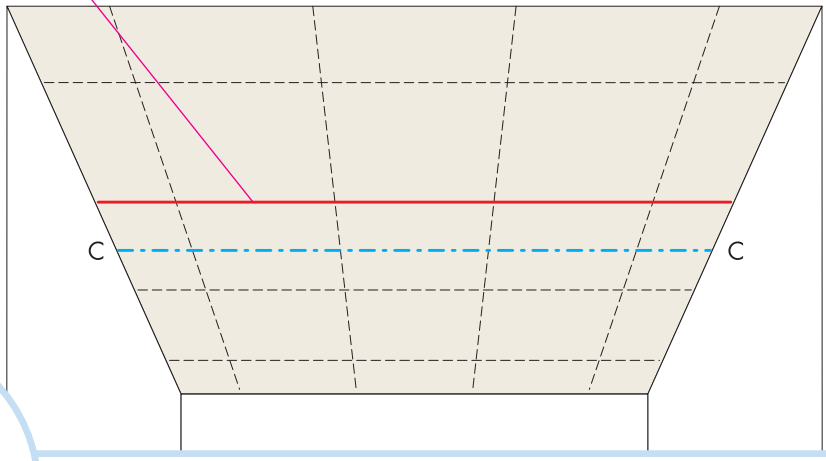

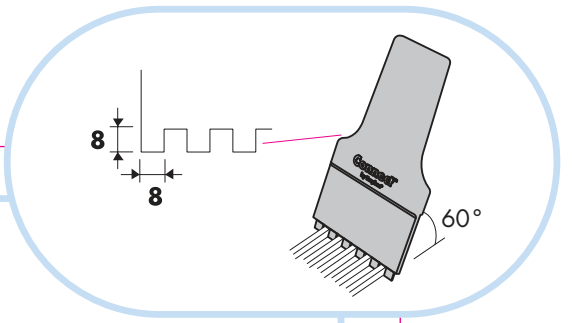
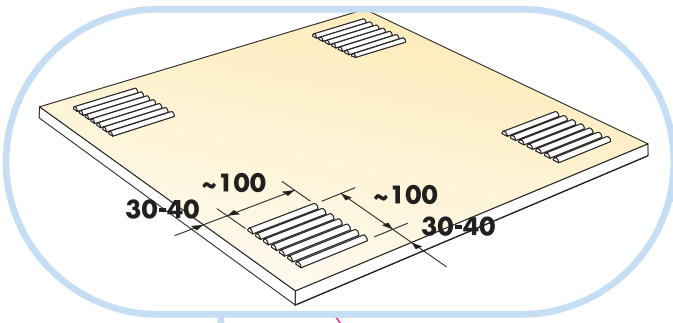

9

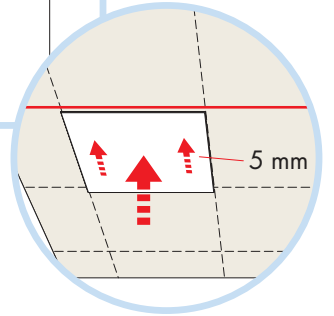
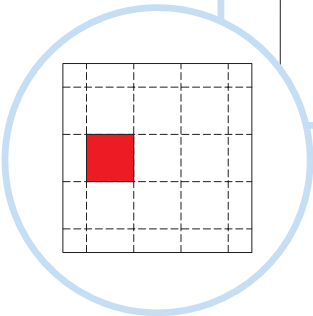
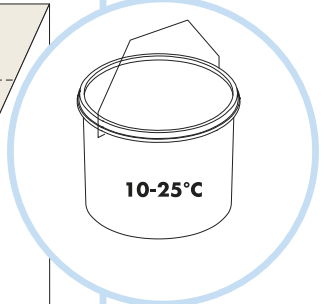
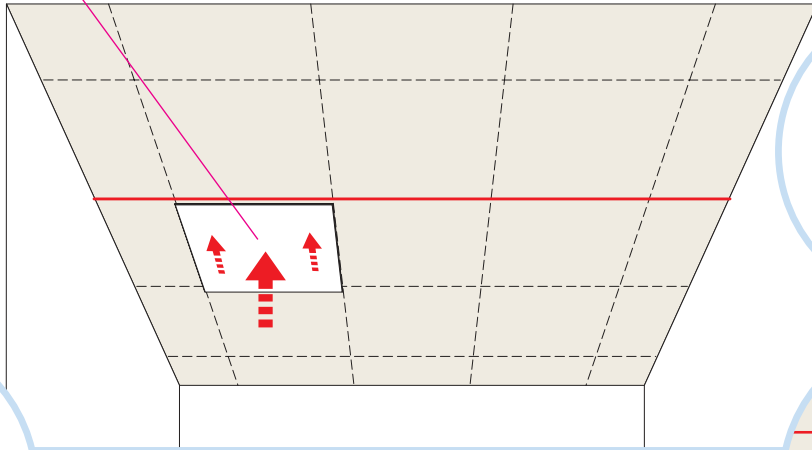

10

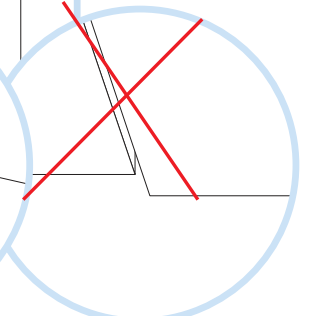
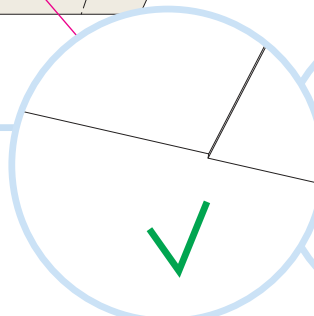
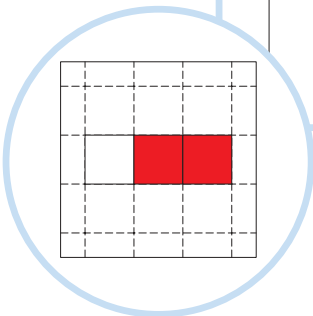
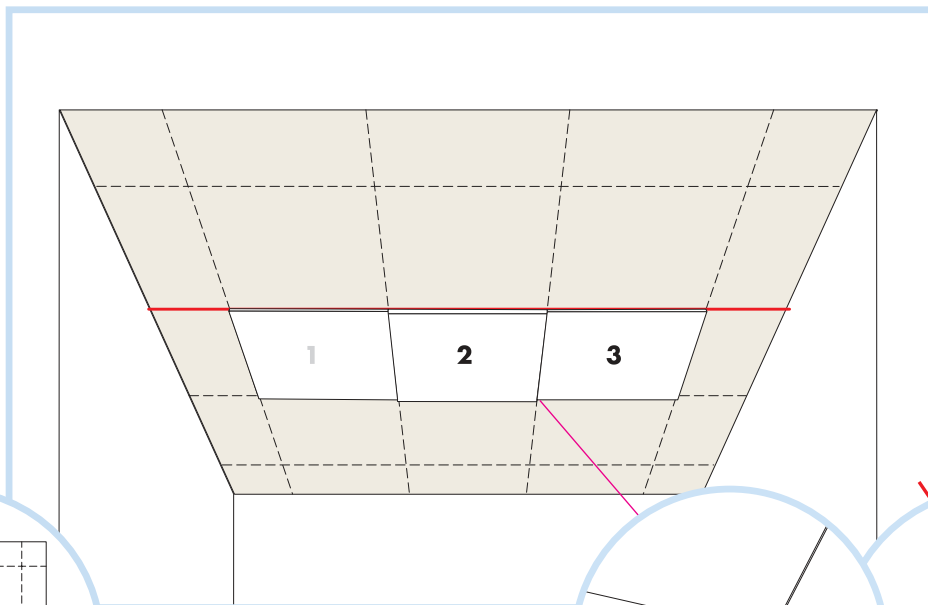

11

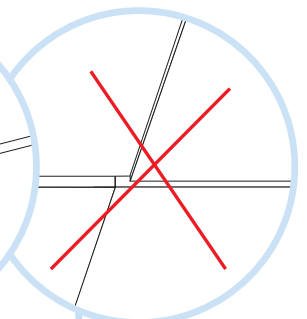
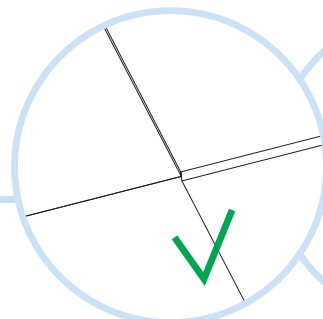
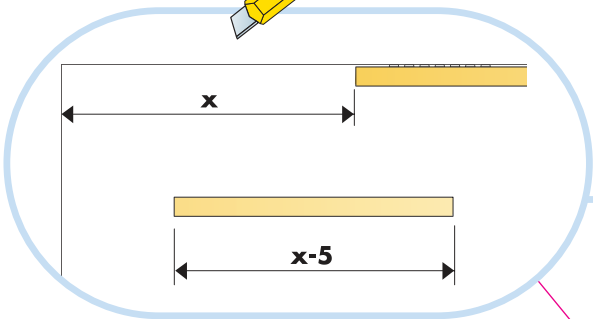
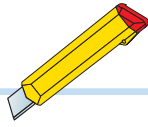
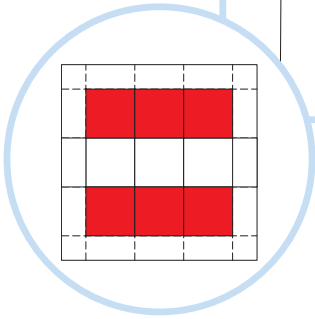
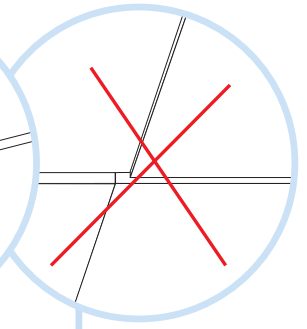
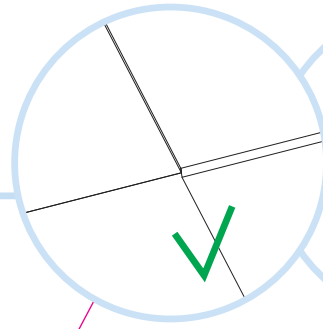
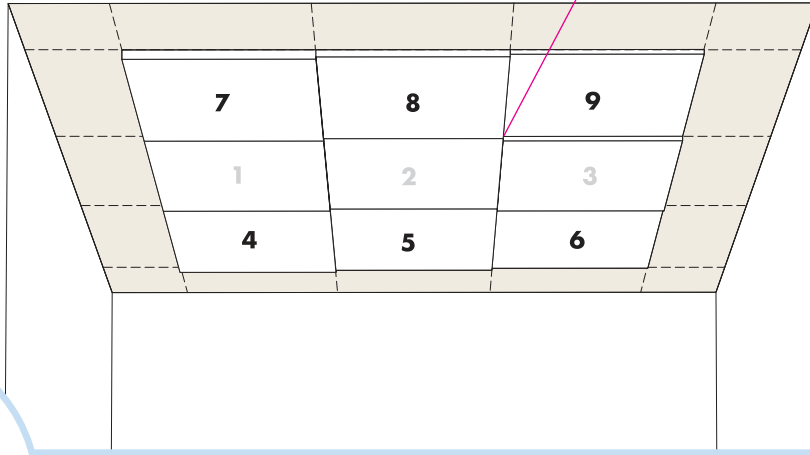

12

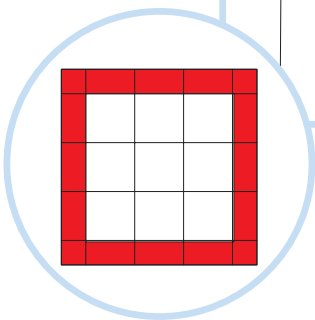

13

