

ECOPHON FOCUS EDGE™ 500

Ecophon Focus Edge™ 500 is a system used as free hanging unit(s) in applications where the installation of a wall-to-wall ceiling is not possible. The system consists of profiles and corners which together form a well designed perimeter trim.

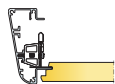

Ecophon Focus Edge™ 500



SYSTEM RANGE

Size, mm	600x600	1200x600	1200x1200	1200x1200
T24	•	•	•	•
Thickness (THK)	20	20	20	25
Inst. Diagr.	M165, M210, M211	M165, M210, M211	M210	M211

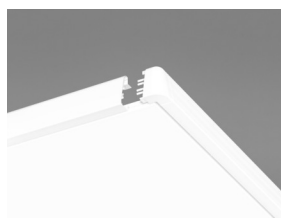

Connect Edge 500 in position for Focus E installation

TYPE OF APPLICATION

- Healthcare
- Education
- Office



ACOUSTIC

Ecophon Focus Edge 500 is a perimeter component. For acoustic data on the system - please see corresponding ceiling system (Focus Ds, Focus Dg or Focus/Master E).



CIRCULARITY

Fully recyclable.



FIRE SAFETY

Country		Class
Europe	EN 13501-1	A1



INSTALLATION

Installed according to installation diagrams, installation guides and drawing aid. For information regarding minimum overall depth of system see quantity specification.



MECHANICAL PROPERTIES

Additional live load has to be fixed to the soffit.



CE

Ecophon ceiling systems are CE marked according to the European harmonized standard EN13964:2014. CE marked construction products are covered by a Declaration of Performance (DOP) which enables customers and users to easily compare performance of products available on the European market.

Suspended island

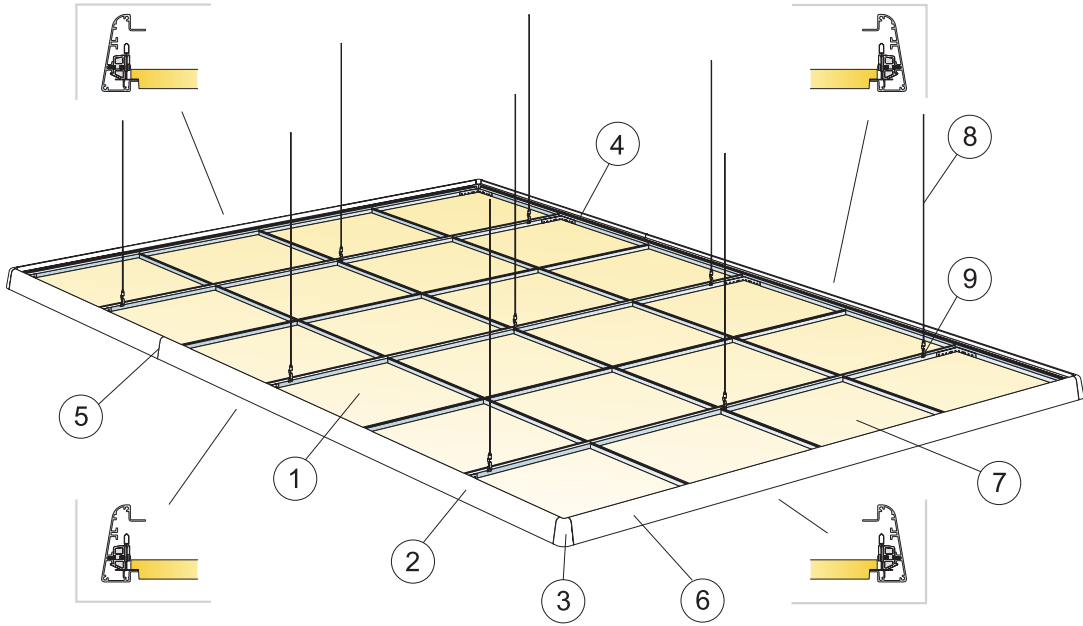

© Ecophon Group

Installation diagram (M165) for Ecophon Edge 500 with Focus E T24

Quantity specification (excl. wastage)

	Size, mm	
	600x600	1200x600
1 Focus E	2,8/m ²	1,4/m ²
2 Connect Edge 500 Profile	as required	as required
3 Connect Edge Corner	as required	as required
4 Connect L-coupling	as required	as required
5 Joint with Guide pins and Joint fixing bracket, (see Edge kit for further details)	as required	as required
6 Connect Edge profile clip E, (18 pcs/kit included in Connect Edge kit E)	as required	as required
7 Focus E tile and Connect grid	as required	as required
8 Connect Adjustable wire hanger, installed at 1200 mm centres	as required	as required
9 Connect Hanger clip	as required	as required
Connect Edge kit E: 18 pcs Connect Edge profile clip with screw RTK 3,5x19, 4 pcs Joint fixing bracket, 1 pc socket screw wrench 2 mm, 1 pc socket screw wrench T10, 12 pcs guide pins, 24 pcs screws RTK ST 3,5x9,5 (for fixing to extrusion), 1 pc installation guide	as required	as required
Not included in kit: Connect L-coupling		
Not included in kit: Connect Installation screw BR for L-coupling		
Δ Min. overall depth of system: 130 mm		
δ Min. demounting depth: See Focus/Master E		

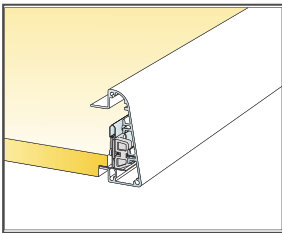
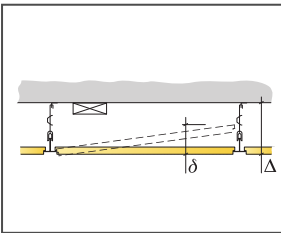

Joint between tile and Edge profile

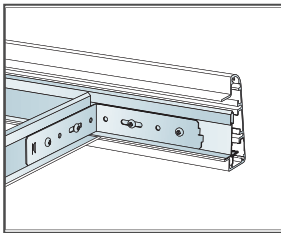

Connection between T-profile and Edge extrusion

Size, mm	Max live load (N)	Min load bearing capacity (N)
600x600x20	50	160
1200x600x20	50	160

Live load/load bearing capacity

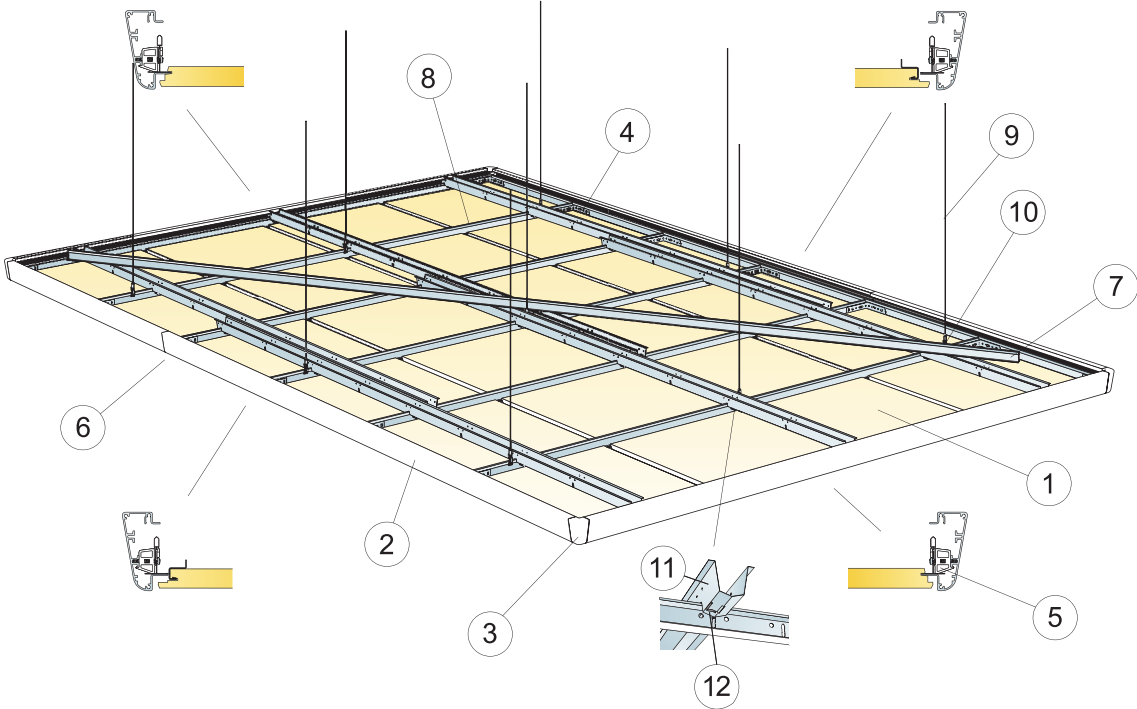

Installation diagram (M210) for Ecophon Edge 500 with Focus Ds

Quantity specification (excl. wastage)

	Size, mm		
	600x600	1200x600	1200x1200
1 Focus Ds	2,8/m ²	1,4/m ²	0,7/m ²
2 Connect Edge 500 Profile	as required	as required	as required
3 Connect Edge 500 Corner	as required	as required	as required
4 Connect L-coupling	as required	as required	as required
5 Connect Edge profile clip, (18 pcs/kit included in Connect Edge kit Ds/Dg)	as required	as required	as required
6 Joint with Guide pins and Joint fixing bracket, (see Edge kit for further details)	as required	as required	as required
7 Connect Main runner for adjustment and stabilisation of grid	as required	as required	as required
8 Focus Ds tile and Connect grid system (see Focus Ds system page for further details)	as required	as required	as required
9 Connect Adjustable wire hanger, installed at 1200 mm centres	as required	as required	as required
10 Connect Hanger clip	as required	as required	as required
11 Connect Space bar	as required	as required	as required
12 Connect Space Bar Winch, installed one per joint Connect Main Runner/Connect Space Bar	1,6/m ²	1,6/m ²	0,8/m ²
Connect Edge Kit Ds/Dg: 18 pcs Connect Edge profile clip with screw RTK 3,5x25, 4 pcs Joint fixing bracket, 1 pc socket screw wrench 2 mm, 1 pc socket screw wrench T10, 12 pcs guide pins, 24 pcs screws RTK ST 3,5x9,5 (for fixing to extrusion), 2 pcs installation guides	as required	as required	as required
Not included in kit: Connect L-coupling			
Not included in kit: Connect Installation screw BR for L-coupling			
Δ Min. overall depth of system: 135 mm			
δ Min. demounting depth: 30 mm (50 mm with 1200x1200)			

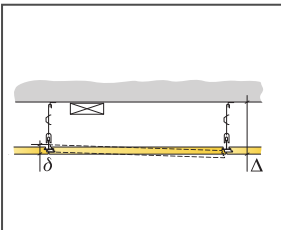

See Quantity Specification

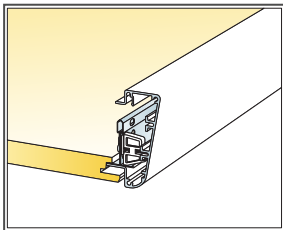

Joint with tile side Ds1

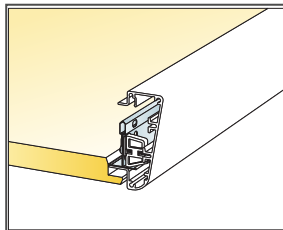

Joint with tile side Ds2 and extra profile

Size, mm	Max live load (N)	Min load bearing capacity (N)
600x600x20	50	160
1200x600x20	50	160
1200x1200x20	50	160

Live load/load bearing capacity

Suspended island

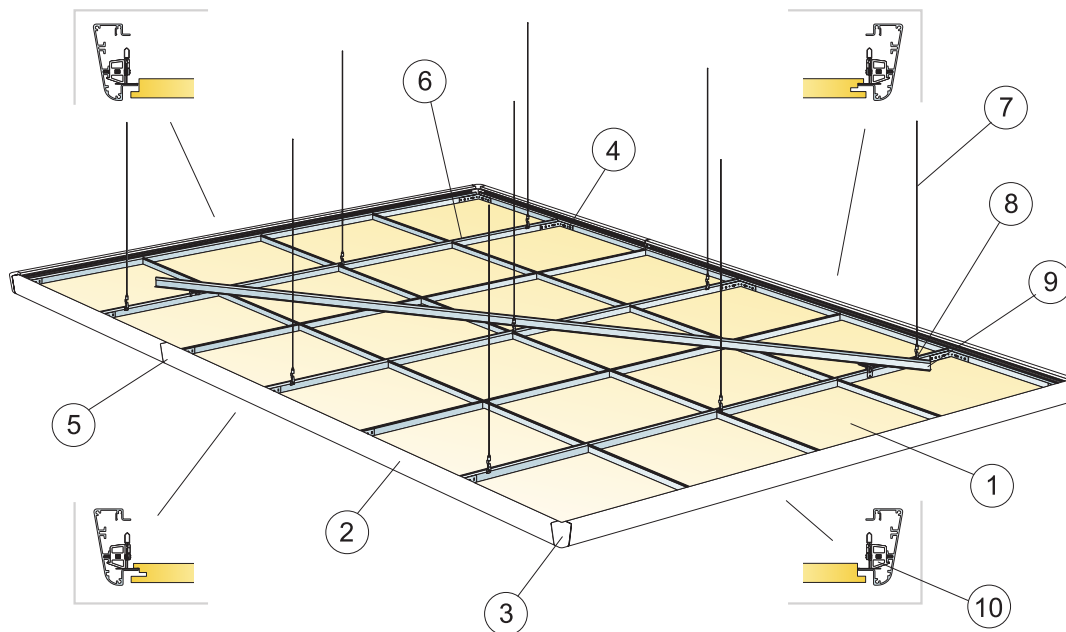

© Saint-Gobain Ecophon AB
Installation diagram (M211) for Ecophon Edge 500 with Focus Dg

Quantity specification (excl. wastage)

	Size, mm		
	600x600	1200x600	1200x1200
1 Focus Dg	2,8/m ²	1,4/m ²	0,7/m ²
2 Connect Edge 500 Profile	as required	as required	as required
3 Connect Edge 500 Corner	as required	as required	as required
4 Connect L-coupling	as required	as required	as required
5 Joint with Guide pins and Joint fixing bracket, (see Edge kit for further details)	as required	as required	as required
6 Focus Dg tile and Connect grid system (see Focus Dg system page for further details)	as required	as required	as required
7 Connect Adjustable wire hanger, installed at 1200 mm centres	as required	as required	as required
8 Connect Hanger clip	as required	as required	as required
9 Connect Main runner for adjustment and stabilisation of grid	as required	as required	as required
10 Connect Edge profile clip, (18 pcs/kit included in Connect Edge kit Ds/Dg)	as required	as required	as required
Connect Edge Kit Ds/Dg: 18 pcs Connect Edge profile clip with screw RTK 3,5x25, 4 pcs Joint fixing bracket, 1 pc socket screw wrench 2 mm, 1 pc socket screw wrench T10, 12 pcs guide pins, 24 pcs screws RTK ST 3,5x9,5 (for fixing to extrusion), 2 pcs installation guides	as required	as required	as required
Not included in kit: Connect L-coupling			
Not included in kit: Connect Installation screw BR for L-coupling			
Δ Min. overall depth of system: 135 mm			
δ Min. demounting depth: 30 mm (50 mm with 1200x1200)			

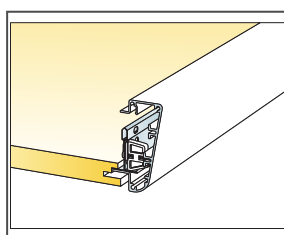
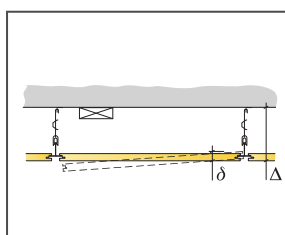

Joint between tile and Edge profile

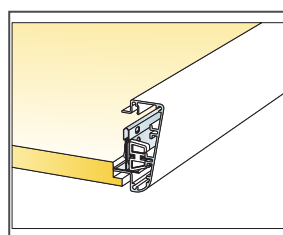

Connection between T-profile and Edge extrusion

Size, mm	Max live load (N)	Min load bearing capacity (N)
600x600x20	50	160
1200x600x20	50	160
1200x1200x25	50	160

Live load/load bearing capacity